

***An Approach for Transferring an  
End-to-End Transport Service  
into a  
Functional Building Block Structure***

---

UNIVERSITÄT  
DUISBURG  
ESSEN

Thomas Dreibholz  
Martin Becke  
Erwin Rathgeb

  
Technische Universität Berlin

Christian Henke

- Motivation
- Functional Building Blocks
- Transport Protocol in a Model of Functional Building Blocks
- Realizing Multipath Transfer
- Containers of a Connection Service
  - Sub-Flow Control Container
  - Flow Control Container
  - Stream Control Container
- Conclusion

# Motivation

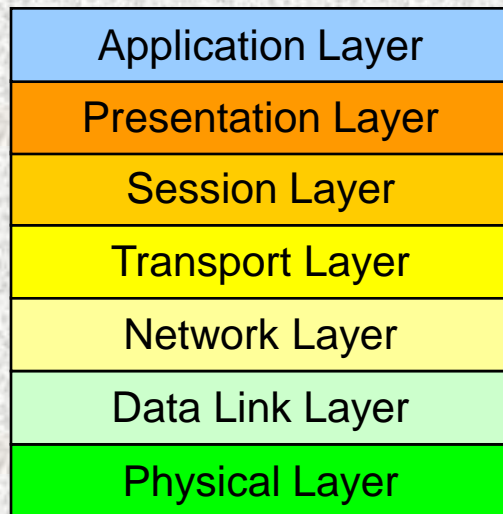

# Motivation

**New/future applications and requirements are not covered well by the classic OSI model!**

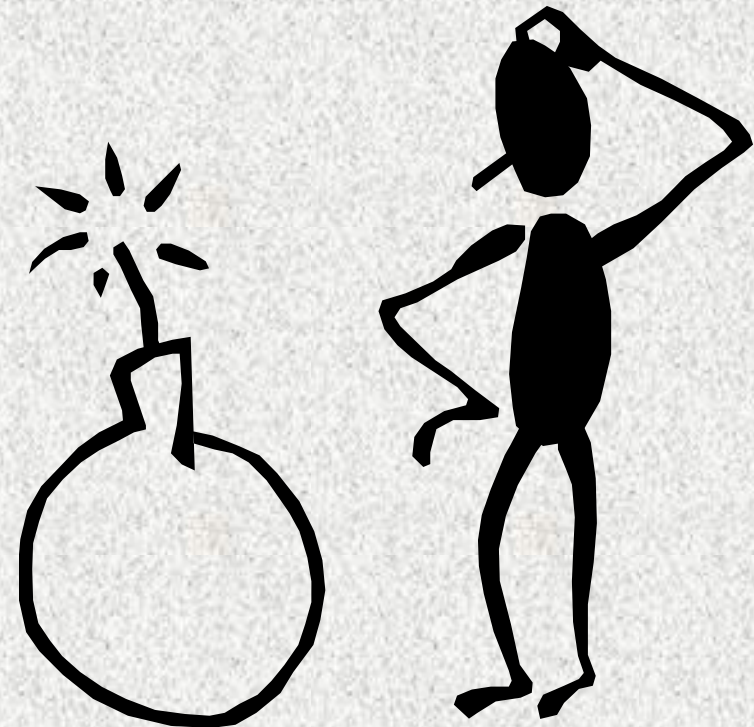
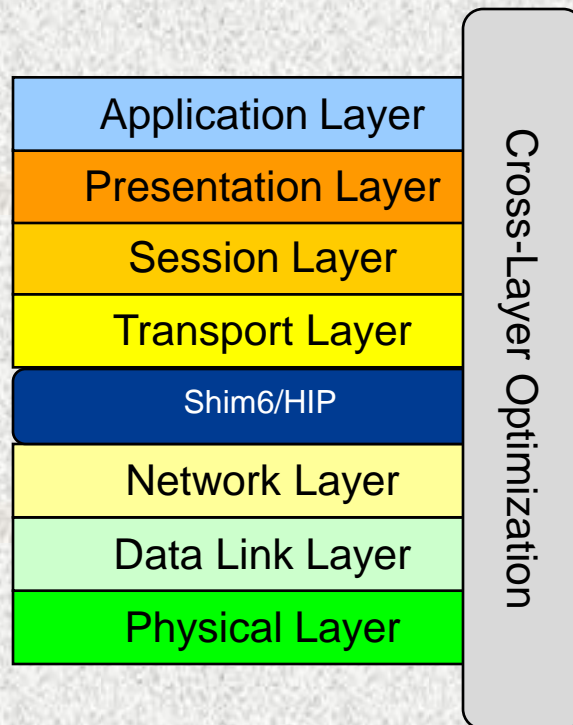

**Let's start with a new approach for the Transport Layer functionalities ...**

## ■ Different approaches

- ANA (**A**utonomic **N**etwork **A**rchitecture)
  - Functional Building Block is an information processing function
  - generates, consumes and/or processes or forwards *information*
- SILO (**S**ervice **I**ntegration **C**ontrol and **O**ptimization)
  - sequence of instructions
  - Functional Building Blocks reflect a certain *functionality* of protocols
- RBA (**R**ole-**b**ased **A**rchitecture)
  - Functional Building Blocks perform some specific functions
  - forwarding and/or processing of *packets*

## ■ Notion of **Basic Functional Building Blocks**

- only conduct *one* specific functionality
- not depend on any other Functional Building Block

## ■ Notion of **Composite Functional Building Blocks**

- conduct functionalities of any granularity

# Transport Protocol in a Model of Functional Building Blocks

- Each Transport Layer protocol can be modelled as a composition of a specific subgroup of Functional Building Blocks
- Protocol represents a specific service of the OSI Transport Layer
  - What are the specific functionalities?
  - What are the dependencies?
  - When is the composition of Functional Building Blocks applied?
    - At design time
      - e.g. 4WARD/Netlets
    - At runtime
      - e.g. Sonate

## ■ Multipath Transfer

- Making use of multiple paths in the network simultaneously, in order to improve data throughput

## ■ Difficult to realize in the current OSI model

- Several protocols tackle identifier/locator separation
- Shim layers to hide multi-path transfer from Transport Layer protocol
- Also within the Transport Layer, multi-path transfer interacts with many functionalities (e.g. reliability, buffer management, QoS/congestion control, ...)

## ■ Idea: Using Functional Building Blocks to model service of Transport Layer

- Service can be extended easily
- Functionalities may be added, removed, extended, modified, ...

# A Look Into a Channel

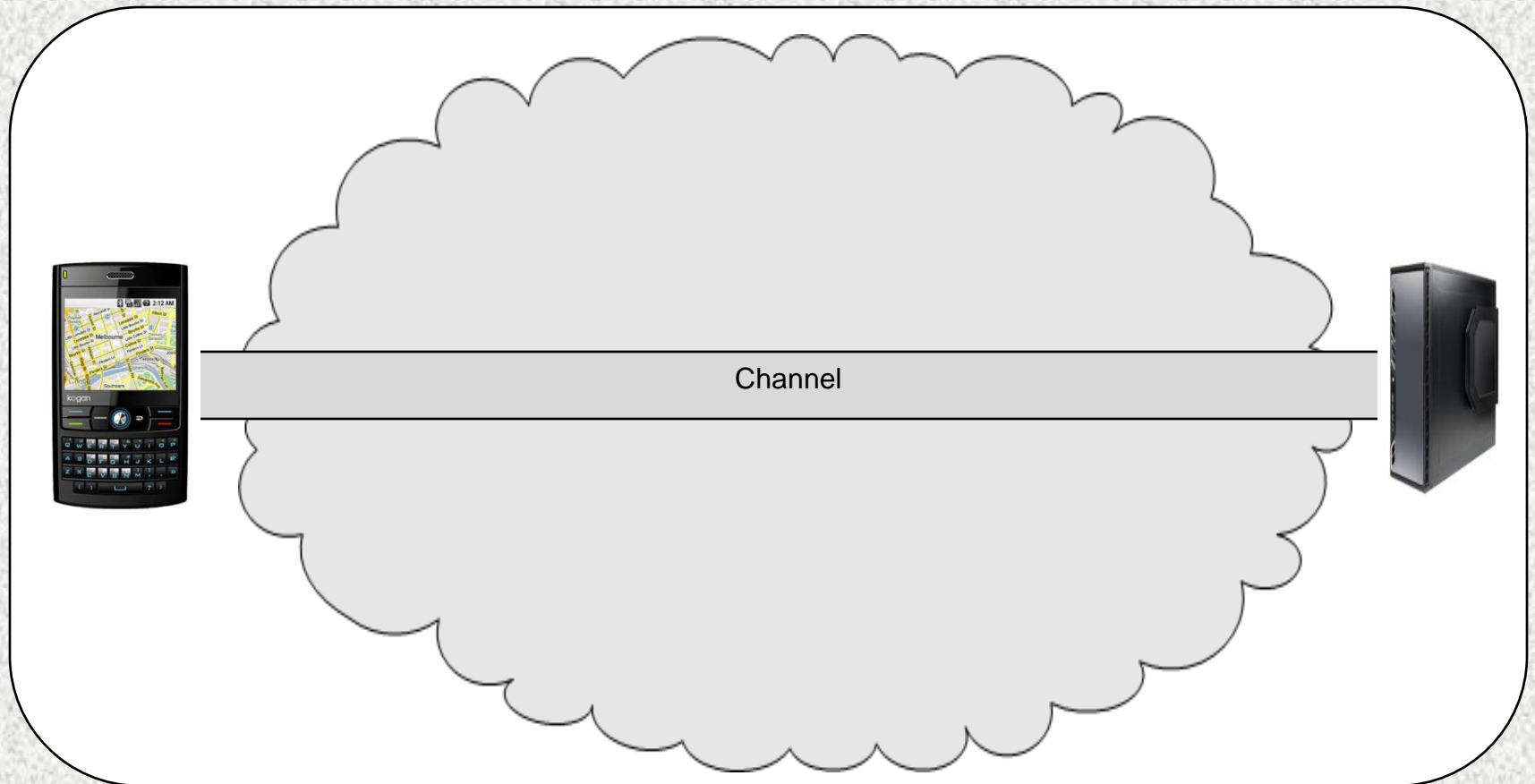

 Data

# A Look Into a Channel

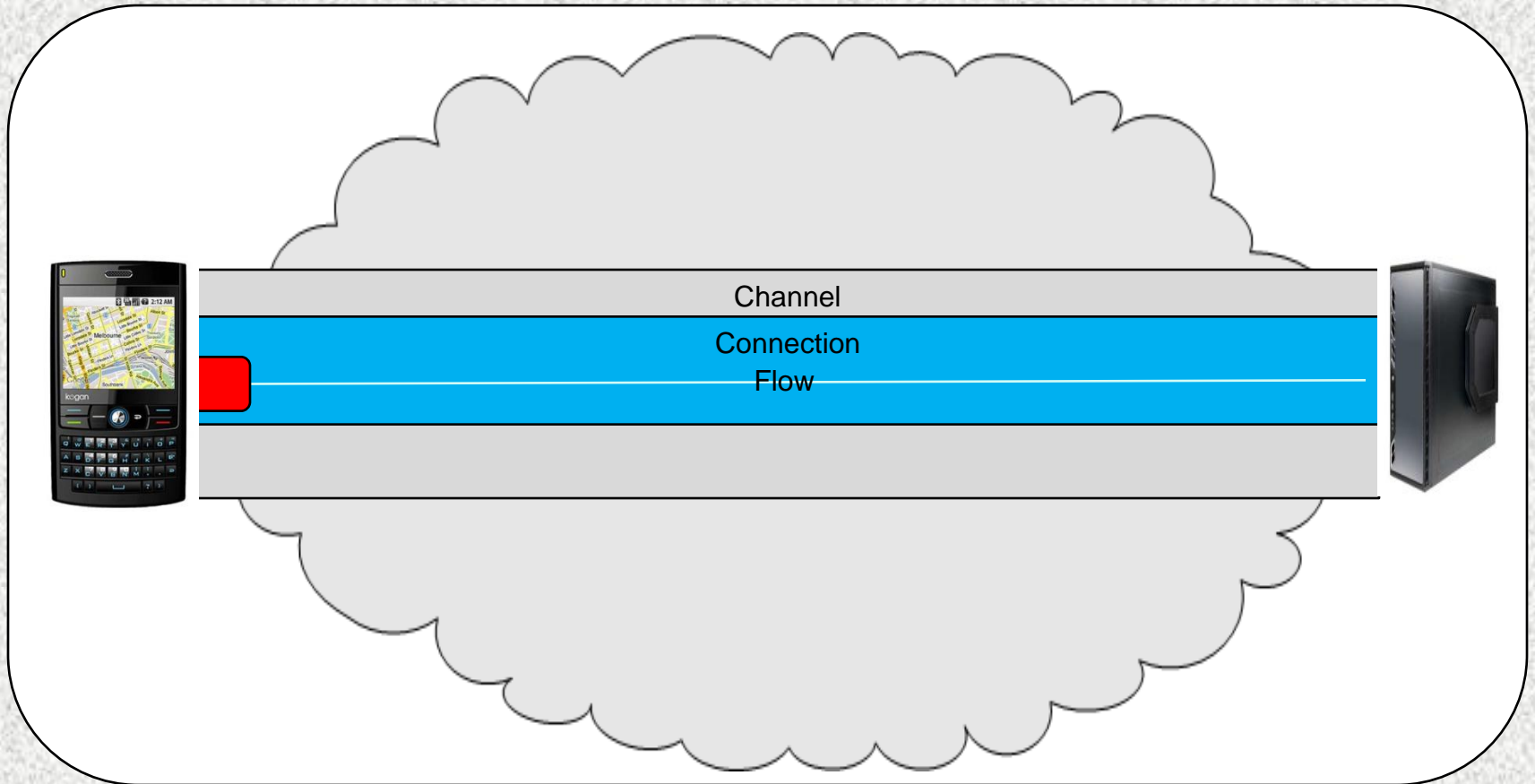

 Data

# A Look Into a Channel

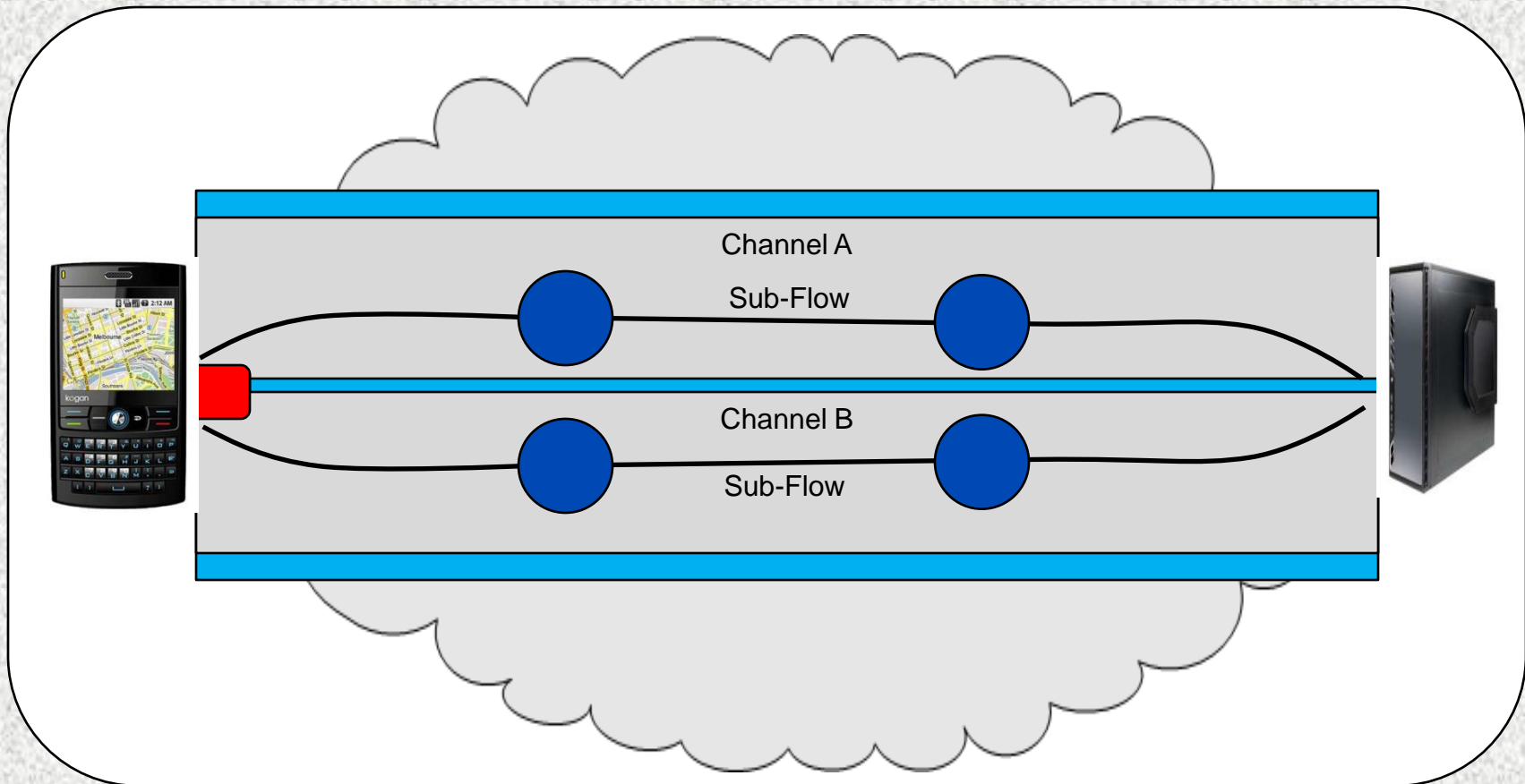

 Data

# A Look Into a Channel

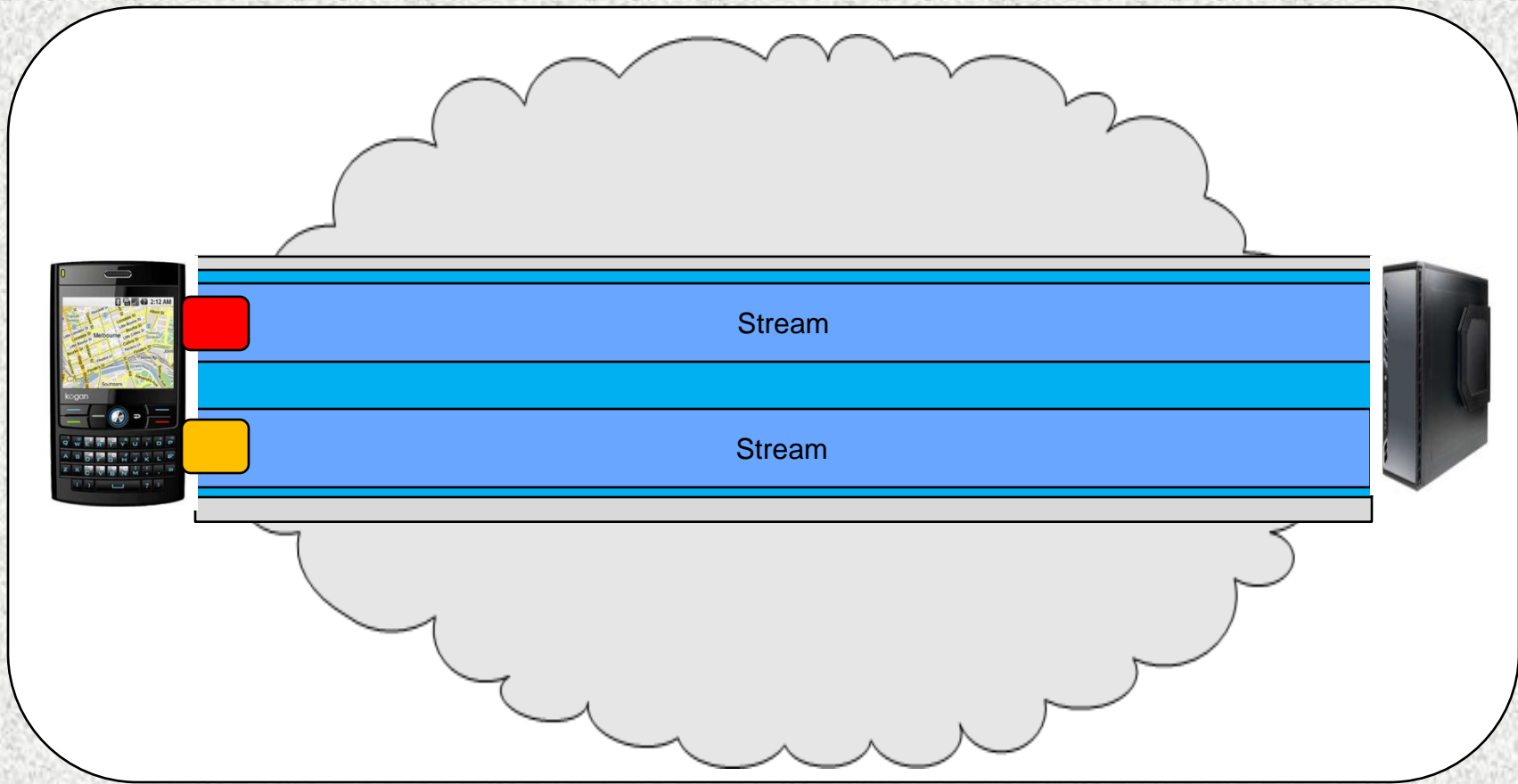

 Data  Data

# Containers of a Connection Service

- **Container = logical combination of Functional Building Blocks**
  - Container is also a Composite Functional Building Block
- **Connection Control Container**
  - Represents the service of a Connection
    - Connections are independent
    - Requires Flow/Sub-Flow(s) and Stream(s) for data transfer
- **Stream Control Container**
  - Represents the service of a Stream
- **Flow Control Container**
  - Represents the service of managing different Sub-Flows
- **Sub-Flow Control Container**
  - Represents the service of a Sub-Flow

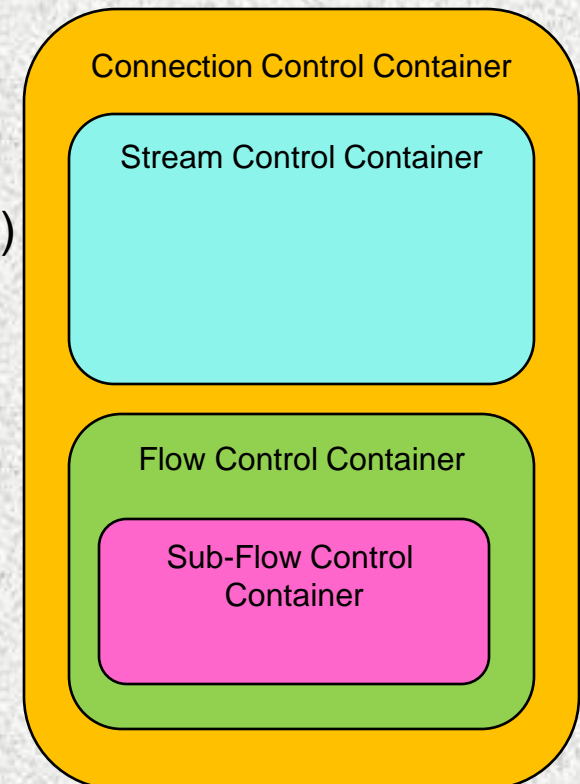

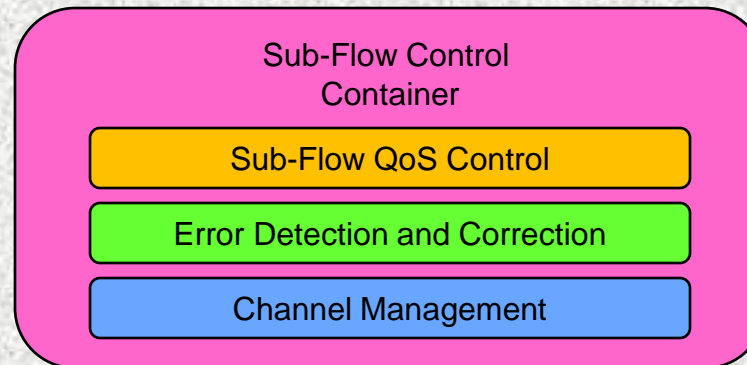

## ■ Sub-Flow QoS Control

- Reservation processing and metering
- Monitoring QoS
- Handling **congestion control**

## ■ Error Detection and Correction

- Detection (and possibly correction) of bit errors in transported data

## ■ Channel Management

- Responsible for the transmission of data over an underlying channel

## ■ Scheduler

- (De-)multiplexes user data fragments of Streams to/from Sub-Flows
- May interact with (Sub-)Flow QoS Control to ensure certain QoS properties

## ■ Acknowledgement

- Reliability of the data transport (triggering retransmissions, partial reliability, ...)

## ■ Buffer Management

- data storage (e.g. for retrans.)

## ■ Security

- Integrity, authenticity and confidentiality

## ■ Flow QoS Control

- Responsible for the QoS of the *whole* flow
- **Resource Pooling** for fairness

## ■ Path Management

- Adding/removing Sub-Flows
- Mobility

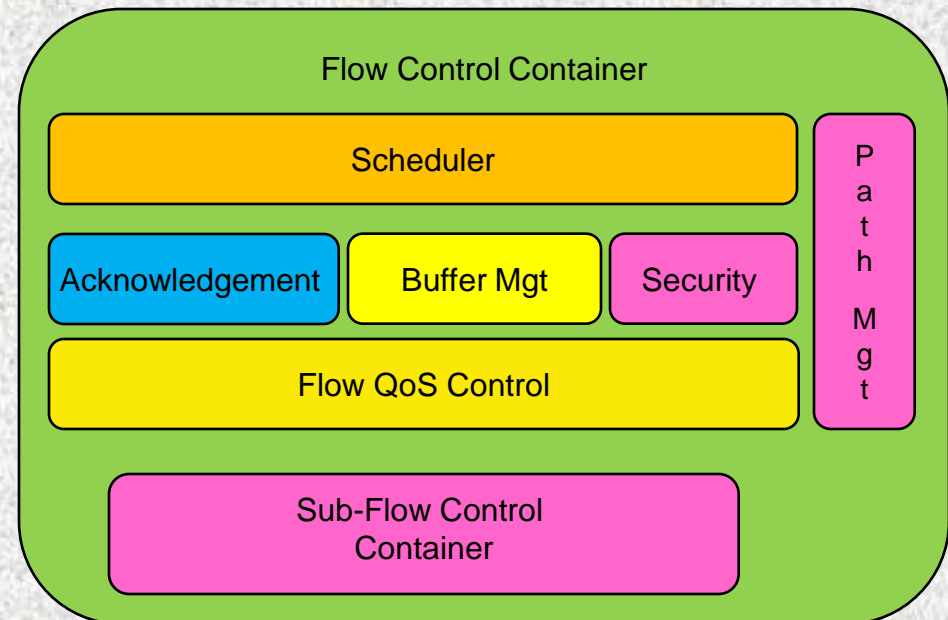

## ■ Ordered Delivery

- Ensures message order within a stream (if required by application)

## ■ Segmentation

- Segmentation and de-segmentation of large user messages
- Interaction with Flow QoS Control and Scheduler for appropriate configuration (e.g. MTU)

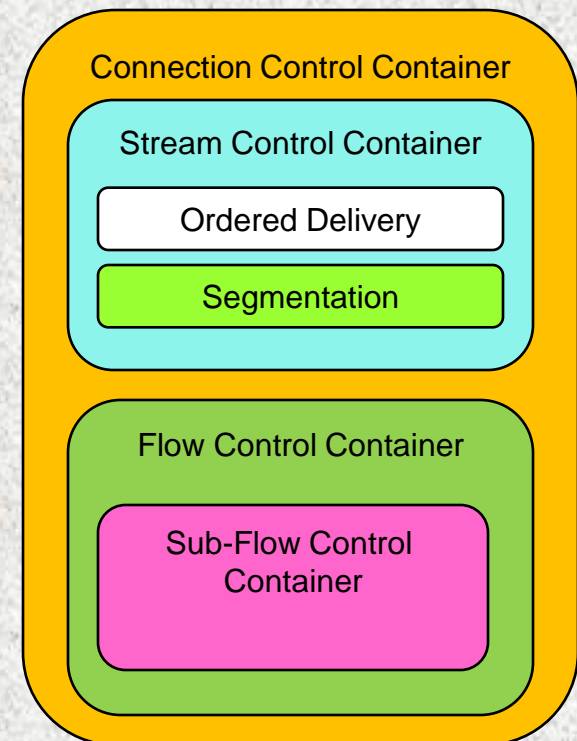

# Functional Building Block Approach for a Connection Service

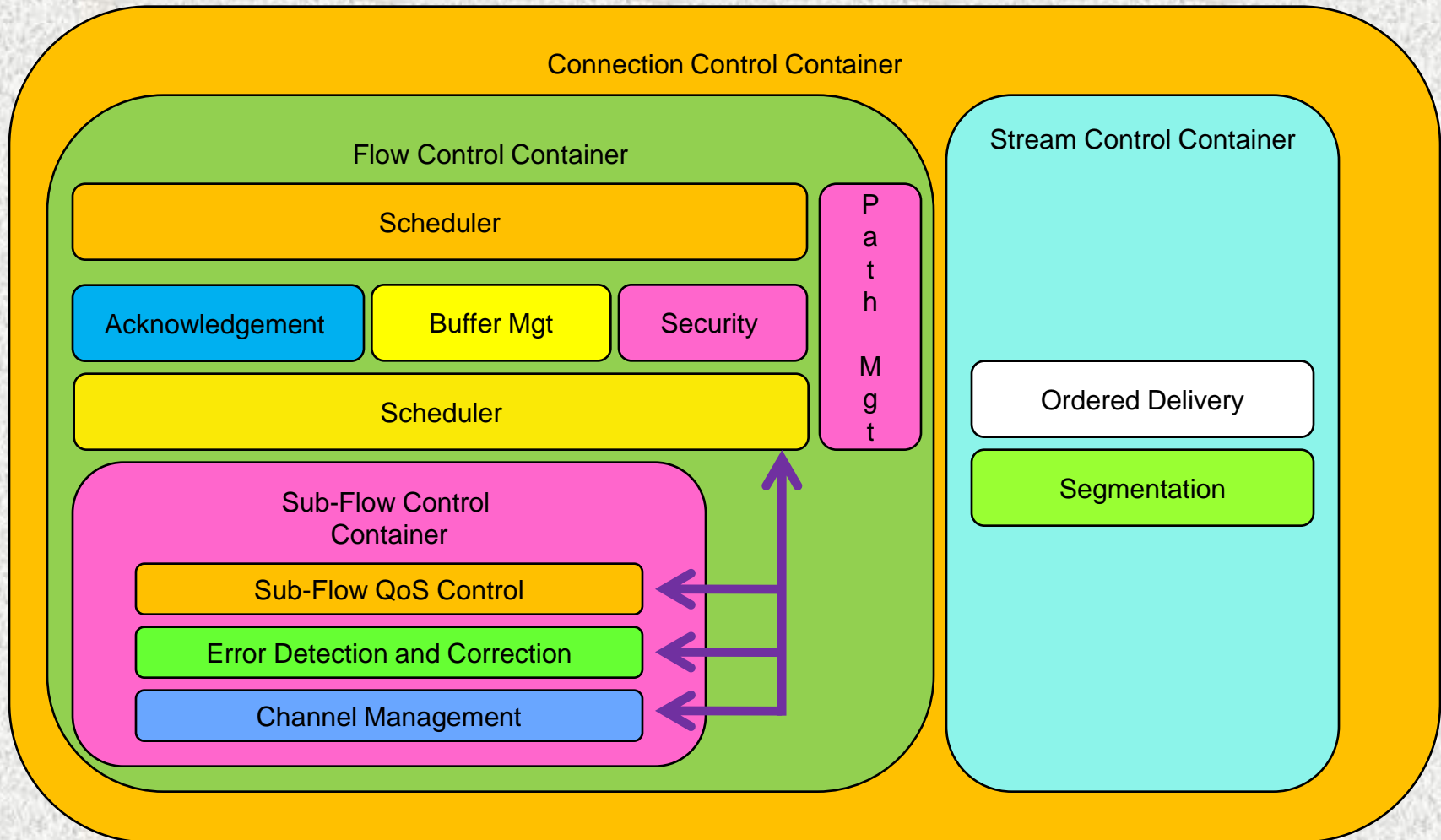

- The classic OSI model is insufficient to cover new applications and protocols
- Functional Building Blocks approach to overcome limitations
  - Extraction of core features into Functional Building Blocks
  - Composite Building Blocks to compose more complex features
  - Containers as logical combination
  - May be adapted when necessary
- Our contribution:
  - Modelling of the **service** provided by the OSI Transport Layer in **Functional Building Blocks**
  - Covers services provided by current state-of-the-art protocols, i.e. UDP, TCP, DCCP and SCTP (including all standardized extensions)
  - Allows to easily add new features, particularly:
    - **Multipath Transfer** and **QoS features**